



# HALLMARK FLOORS®



THE QUALITY MARK IN WOOD FLOORING

# WELCOME TO HALLMARK FLOORS

Welcome to Hallmark Floors World of Beautiful Flooring

Ever since our inception in 1998, Hallmark Floors continues to be driven by our love for wood and our passion for developing, producing and offering the most beautiful, smart and innovative flooring.

Handcrafted in small batches by professional hardwood craftsmen, our wood floor collections are developed and designed to enhance the beauty of all types of homes and interiors, from cozy and traditional to cool and contemporary living.

Our relentless work and the development of our flooring collections have made us one of the fastest growing wood flooring companies in the market, and we are pleased and proud to offer you over 100 uniquely designed hardwood floors.







# CONTENT



- 6** True Engineered Hardwood Flooring
- 10** Organic Engineered 567 Hardwood Flooring
- 14** Avenue Engineered Hardwood Flooring
- 18** Alta Vista Engineered Hardwood Flooring
- 22** Ventura Engineered Hardwood Flooring
- 26** Monterey Engineered Hardwood Flooring
- 30** Novella Engineered Hardwood Flooring

- 34** Grain & Saw Engineered Hardwood Flooring
- 38** Regatta Waterproof Core Hardwood Flooring
- 42** Chaparral Engineered Hardwood Flooring
- 46** Silverado Engineered Hardwood Flooring
- 50** Organic Solid Hardwood Flooring
- 54** Crestline Solid Hardwood Flooring
- 58** Technical



# TRUE

## ENGINEERED HARDWOOD FLOORING

### THE TRUE DIFFERENCE

Hallmark Floors is the first to master this revolutionary technology of replicating “the bog-wood process” that occurs when logs lie buried in lakes, river, and waterways, deprived of oxygen and sunlight. This process in nature can take centuries for the wood to turn from its natural color to deep golden brown or even completely black.

Hallmark Floors has emulated nature’s methods to create saturated colors throughout the wear layer, creating stunning, weathered patinas.

PLANK DIMENSIONS: 7½" x 6'2" RL



ONYX OAK



GARDENIA OAK

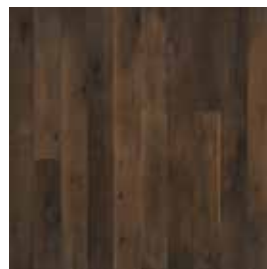

NEROLI OAK



LEMON GRASS OAK



SILVER NEEDLE OAK



ORANGE BLOSSOM HICKORY



MAGNOLIA HICKORY



JASMINE HICKORY



GINGER LILY OAK



JUNIPER MAPLE



ORRIS MAPLE

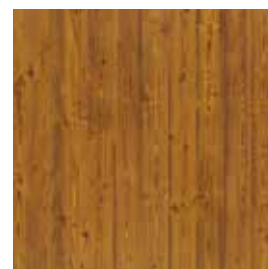

AMBER PINE

MINERAL ENHANCED FLOOR  
FOR MORE INFORMATION ABOUT LIGHT EXPOSURE & NATURAL CHANGES, SEE PAGE 50.

FOR MORE INSPIRATION AND INFORMATION: [HALLMARKFLOORS.COM](http://hallmarkfloors.com)





Unlike other wood floors, the color and beauty of this unique collection goes throughout the wear layer without using stains or dyes.

True bog-wood, driftwood, and weathered barn wood are all very rare. Hallmark has replicated this process and made these prized finishes available through the True Collection.



AMBER PINE



ORANGE BLOSSOM HICKORY

#### BENEFITS

- Nu Oil® - Super-Matte Finish- No recoat at time of install
- Color goes all the way through to the core
- Completely VOC neutral
- Renewable w/ Warranty intact
- MG3 - 2 Guaranteed sandings
- Highest possible stability w/ sawn cut face
- Truecore® 2 - Core material made with quarter sawn pine lamella's
- Guaranteed Third Party Certification
- Green Certification
- Lifetime Structural Guarantee





# ORGANIC 567

ENGINEERED HARDWOOD FLOORING

SIMPLY  
AUTHENTIC

The Organic 567 Collection combines modern hardwood fashion trends with the naturally weathered visuals of reclaimed wood. This collection of engineered wood flooring features planks of random widths and lengths, creating a charming and rustic look that perfectly compliments contemporary designs.

These floors are carefully handcrafted using various techniques to accentuate the striking characteristics of the raw wood material, resulting in a beautiful and lively floor with a genuine wood texture.

PLANK DIMENSIONS: 5", 6", 7½" x 6'2" RL



GUNPOWDER OAK\*



CHAI OAK\*

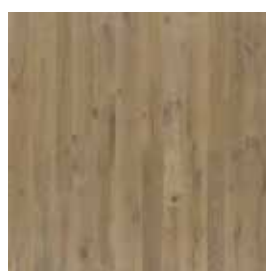

PEKOE OAK\*



HIBISCUS OAK\*

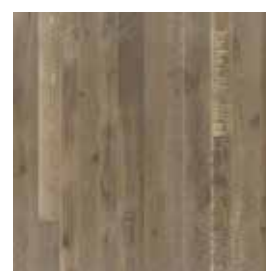

GINSENG OAK\*



EUCALYPTUS LEAF OAK\*

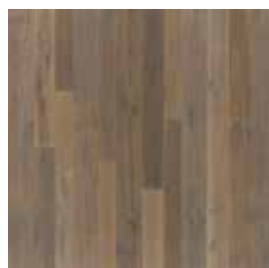

MARIGOLD OAK\*



CHAMOMILE HICKORY



DARJEELING HICKORY



OOLONG HICKORY

\*FUMED FLOOR  
FOR MORE INFORMATION ABOUT FUMED PRODUCTS, SEE PAGE 50.







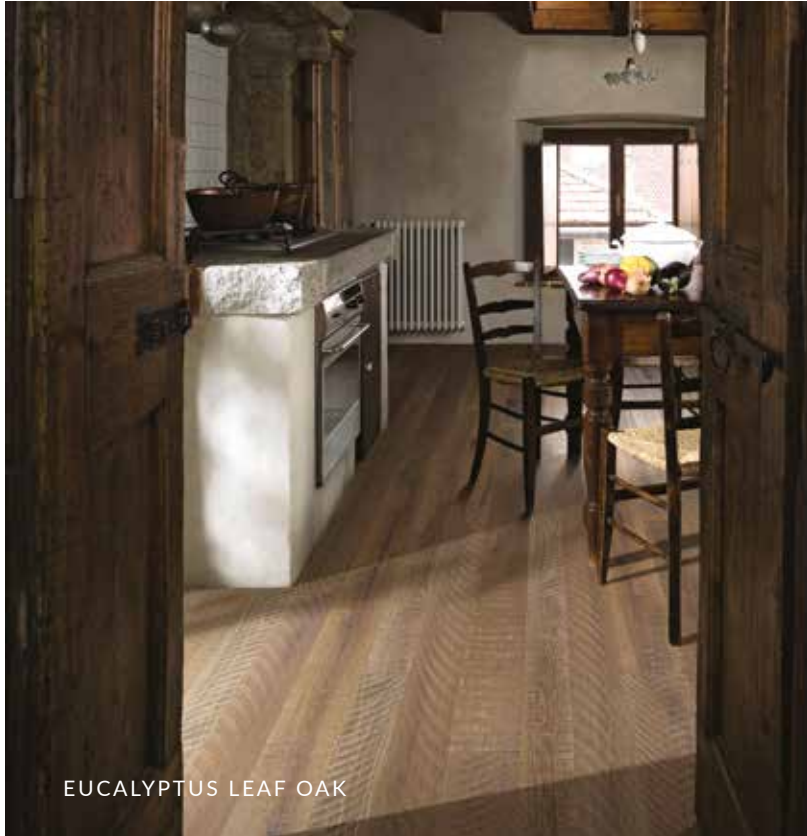

EUCALYPTUS LEAF OAK

“We absolutely love our floors. So durable as we have two large dogs and we have not seen a scratch yet! Even if you did get a scratch it would be easy to blend in with the rustic look of the floor. We could not be happier. Thank you!!”

- Robin H.  
Homeowner, Canadaiga NY



GINSENG OAK



HIBISCUS OAK

**BENEFITS**

- Nu Oil® Finish – No recoat at time of install
- High stain protection & color retention
- Completely VOC free
- Renewable w/ Warranty intact
- MG4 – 3 Guaranteed sandings
- Highest possible stability w/ sawn cut face
- Guaranteed Third Party Certification
- Truecore® – Renewable Resources
- Green Certification
- Lifetime Structural Guarantee





OOLONG HICKORY

# AVENUE

## ENGINEERED HARDWOOD FLOORING

### ULTRA WIDE PLANKS

As big as your own imagination, the Ultra Wide Avenue Collection removes the constraints of conventional flooring allowing your space to breathe. Each plank exudes more history and beauty of nature's strongest and most dramatic hardwood species only available in wider widths.

With supreme styling and trend setting colors the Avenue Collection offers 10 beautiful visuals in a variety of species, including European Oak, American Hard Maple and American Hickory. These true sawn cut floors boast the longevity of a solid floor with the security of Hallmark's proprietary engineering prowess to give your home the floor of a lifetime.

PLANK DIMENSIONS: 9½" x 7'2" RL



SUNSET OAK\*



RODEO OAK\*



OCEAN DRIVE OAK\*



MULHOLLAND OAK\*



WILSHIRE OAK\*



MICHIGAN HICKORY



BELLE MEADE HICKORY



NEWBURY HICKORY



PENNSYLVANIA MAPLE



LOMBARD MAPLE

\*FUMED FLOOR  
FOR MORE INFORMATION ABOUT FUMED PRODUCTS, SEE PAGE 50.









SUNSET OAK

The Avenue Collection shows the widest 4mm sawn cut Oak, Maple & Hickory options in the industry. 150+ year old trees are harvested to make this ultra wide plank collection. It is the only product comparable to a 4mm sawn cut face solid wood on the market.



MULHOLLAND OAK



RODEO OAK

**BENEFITS**

- TrueMark® Glaze Tek Finish
- 10x more durable than UV Poly
- Completely VOC neutral
- Renewable w/ Warranty intact
- MG4 – 3 Guaranteed sandings
- Highest possible stability w/ sawn cut face
- Guaranteed Third Party Certification
- Truecore® – Renewable Resources
- Green Certification
- Lifetime Structural Guarantee





BELLE MEADE HICKORY

# ALTA VISTA

## ENGINEERED HARDWOOD FLOORING

SIMPLY  
INNOVATIVE

The Alta Vista collection is a return to vintage European design. These beautiful, classic and refined floors are crafted out of European White Oak, a premier hardwood species that has been used for everything from flooring to shipbuilding over the centuries due to its stability.

These floors feature Hallmark's authentic sawn-cut style and are lightly sculpted and wire brushed by hand. The boards are generous widths and lengths, and the surface is treated with our exclusive Nu Oil® finish for a classic style and elegance.

PLANK DIMENSIONS: 7½" x 6'2" RL



BALBOA OAK\*



DEL MAR OAK\*



LAGUNA OAK



MALIBU OAK\*



LA JOLLA OAK\*

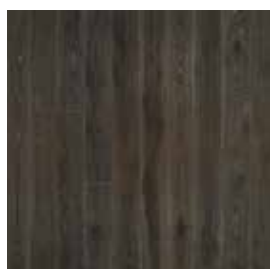

CARLSBAD OAK\*



OJAI OAK\*



BIG SUR OAK\*



CAMBRIA OAK\*

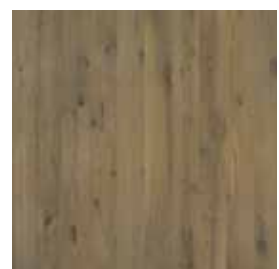

PISMO OAK\*

\*FUMED FLOOR  
FOR MORE INFORMATION ABOUT FUMED PRODUCTS, SEE PAGE 50.







BIG SUR OAK





“I have been in the design and remodeling industry for over 20 years and no other product compares to the Hallmark Floors Alta Vista Collection. The quality is unparalleled, and from a designer’s perspective it is a dream product to incorporate into any design.”

- Jim D.  
Designer, Columbus OH



CARLSBAD OAK

**BENEFITS**

- Nu Oil® Finish- No recoat at time of install
- High stain protection & color retention
- Completely VOC neutral
- Renewable w/ Warranty intact
- MG4 - 3 Guaranteed sandings
- Highest possible stability w/ sawn cut face
- Guaranteed Third Party Certification
- Truecore® - Renewable Resources
- Green Certification
- Lifetime Structural Guarantee

# VENTURA

## ENGINEERED HARDWOOD FLOORING

### SIMPLY NATURAL

The understated elegance and durability of the Ventura collection's oak, maple and hickory planks feature two unique finishes that are further enhanced by wide planks and natural variation.

This contemporary collection was designed to look gently aged and weathered, while remaining durable and stain resistant.

Hallmark's 2mm thick slice-cut style, combined with a wire brushed texture applied by hand, offers a truly natural look for modern living.

PLANK DIMENSIONS: 7½" x 6'2" RL

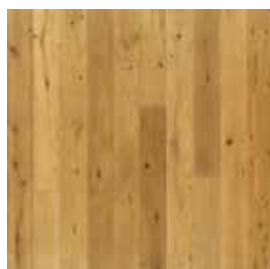

MARINA OAK\*



MANGROVE OAK\*



SANDAL OAK\*



SEASHELL OAK\*



PEARL OAK\*



CATAMARAN HICKORY



SANDBAR HICKORY



TIDE POOL MAPLE



SAND CASTLE MAPLE

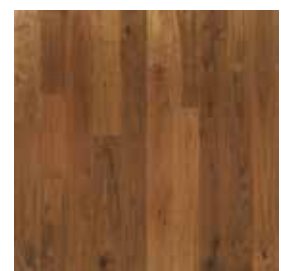

MARITIME WALNUT

\*FUMED FLOOR  
FOR MORE INFORMATION ABOUT FUMED PRODUCTS, SEE PAGE 50.









CATAMARAN HICKORY

“We recently purchased a new construction home with Hallmark Floors on the first and second levels, specifically the Ventura collection. The floors are incredible and, even though the home has a ton of really cool features, the first thing people mention is the floors. I have already recommended them to family and friends.”

- Shawn D.  
Homeowner, Arlington VA



SANDAL OAK



**BENEFITS**

- Nu Oil® Finish – No recoat at time of install (Oak)
- TrueMark® Glaze Tek Finish (Hickory, Maple, Walnut)
- Completely VOC neutral
- Renewable w/ Warranty intact
- MG2 – 2 Guaranteed sandings
- Highest possible stability w/ slice cut face
- Guaranteed Third Party Certification
- Truecore® – Renewable Resources
- Green Certification
- Lifetime Structural Guarantee





# MONTEREY

## ENGINEERED HARDWOOD FLOORING

SIMPLY  
SAVVY

Industry-leading technology enhances the beauty of nature in the Monterey Collection, which adds a modern twist to a historical, European design influence. The floors are meticulously crafted out of maple, hickory and oak, combining planks of random widths (4", 6", 8") and lengths (up to 6'2").

Each individual plank is carefully sculpted and wire brushed by hand, using our 2mm slice-cut style. The low-luster Truemark® Glaze Tek finish enhances durability of these fashionable floors.

PLANK DIMENSIONS: 4", 6", 8" x 6' RL



TERRENO OAK

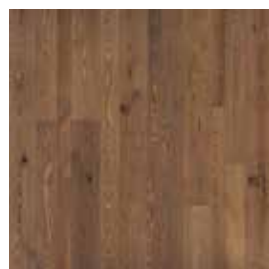

CHALET RED OAK



TERRACOTTA RED OAK



CASITA HICKORY



GAUCHO HICKORY



PUEBLA HICKORY

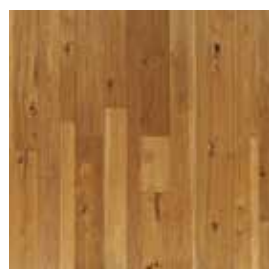

RANCHERO HICKORY



BACCARRA MAPLE



BUNGALOW MAPLE



CABALLERO MAPLE











RANCHERO HICKORY

**BENEFITS**

- TrueMark® Glaze Tek Finish
- 10x more durable than UV Poly
- Completely VOC neutral
- Renewable w/ Warranty intact
- MG2 – 2 Guaranteed sandings
- Highest possible stability w/ slice cut face
- Guaranteed Third Party Certification
- Truecore® – Renewable Resources
- Green Certification
- Lifetime Structural Guarantee

# NOVELLA

## ENGINEERED HARDWOOD FLOORING

SMART,  
MODERN,  
CAPTIVATING

The innovative and versatile Novella Hardwood Collection creates a multitude of options through offering two finishes, three wood species and an array of captivating colors. The planks made from maple and hickory are treated with the TrueMark® Glaze Tek finish, providing a low-sheen luster, while the oak products are finished with Nu Oil®, Hallmark's exclusive oil finish.

The Novella floors feature our slice-cut style, with boards that have been lightly sculpted by hand (maple & hickory) or wire brushed (oak), with detailed coloring. This versatile collection was designed to fit any design scheme and compliment any lifestyle.

PLANK DIMENSIONS: 6" x 6'2" RL



EMERSON OAK\*



WHITMAN OAK\*



ALCOTT MAPLE



WILLIAMS MAPLE



RAND HICKORY



FAULKNER HICKORY



THOREAU HICKORY



HAWTHORNE OAK\*



FROST MAPLE

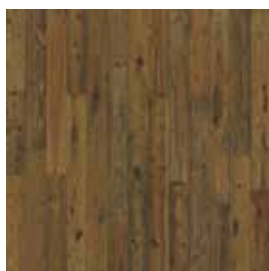

ELIOT HICKORY



HEMINGWAY OAK\*



TWAIN OAK\*

\*FUMED FLOOR  
FOR MORE INFORMATION ABOUT FUMED PRODUCTS, SEE PAGE 50.









THOREAU HICKORY





FAULKNER HICKORY

“We are absolutely loving our new Hallmark Novella Twain floors. The color is so rich and warm and the finish is absolutely stunning. Working with Hallmark has been so easy and pleasant and we look forward to our new floors for a long time to come”

- Carol W.  
Homeowner,  
Canal Winchester OH



TWAIN OAK

#### BENEFITS

- Nu Oil® Finish – No recoat at time of install (Oak)
- TrueMark® Glaze Tek Finish (Hickory, Maple, Walnut)
- Completely VOC neutral
- Renewable w/ Warranty intact
- Highest possible stability w/ slice cut face
- Guaranteed Third Party Certification
- Truecore® – Renewable Resources
- Green Certification
- Lifetime Structural Guarantee

# GRAIN & SAW

ENGINEERED HARDWOOD FLOORING

RUSTIC &  
ELEGANT

Grain & Saw is a subtle reclaimed look inspired by 14th-century handcrafted guilds, paired with the latest materials this collection will compliment every interior. At a time when Guild associations worked with merchants and artisans to protect one of kind handcrafted products the touch & feel of the work is unmistakably rich. Every board is unique, every pattern is distinct and full of personality... designed with juxtaposing striking characteristics of hand tooled saw marks and enhanced natural grain allowing the ebbs and flows of the wood species to be at the forefront.

PLANK DIMENSIONS: 6" x 6'2" RL



MORRIS OAK\*

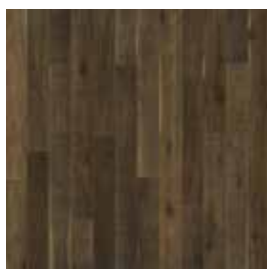

RUSKIN OAK\*



BALLENTINE OAK

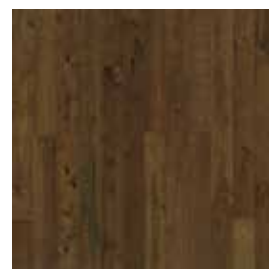

LARSSON HICKORY

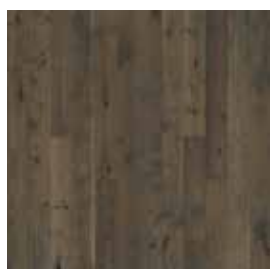

HOFFMAN HICKORY

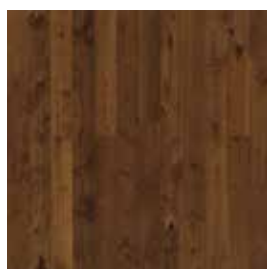

STICKLEY HICKORY



TIFFANY MAPLE

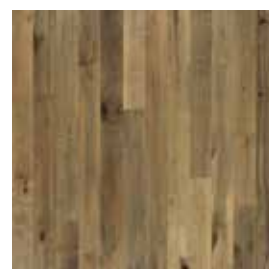

GREENE MAPLE

\*FUMED FLOOR  
FOR MORE INFORMATION ABOUT FUMED PRODUCTS, SEE PAGE 50.

FOR MORE INSPIRATION AND INFORMATION: [HALLMARKFLOORS.COM](http://HALLMARKFLOORS.COM)













TIFFANY MAPLE

#### BENEFITS

- TrueMark® Glaze Tek Finish
- Completely VOC neutral
- Renewable w/ Warranty intact
- Highest possible stability w/ slice cut face
- Guaranteed Third Party Certification
- Truecore® – Renewable Resources
- Green Certification
- Lifetime Structural Guarantee

# REGATTA

## HARDWOOD FLOORING

### SPILL PROOF WOOD FLOOR

Our fashionable looks are created with hand-applied glazes, skip sawn textures, hand-scraped surfaces and nature's graining accented by our unique brushing techniques. Our Regatta Hardwood features our Spill Proof guarantee, our durable finish and an edge sealant that provides 360 degree protection making for an easy clean up to life's little mishaps.

PLANK DIMENSIONS: 6" x 6'2" RL



ANCHOR OAK



HARBOR OAK

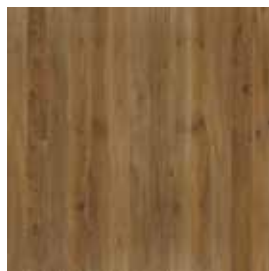

LEEWARD OAK



HALYARD OAK



SPINNAKER OAK



SAILMAKER MAPLE



BALLAST MAPLE



COMPASS MAPLE



STARBOARD HICKORY

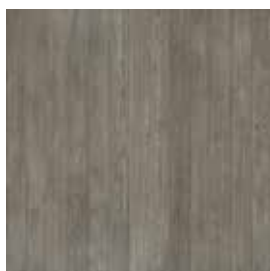

WINDWARD HICKORY



PORT HICKORY



KETCH HICKORY









HARBOR OAK

Regatta also features the “push lock“ fastening system for extra seam protection and a perfect installation every time. As a finishing touch, we’ve added our Quiet Comfort padding to each board for added underfoot comfort and sound reduction.



STARBOARD HICKORY

- BENEFITS**
- TrueMark® Glaze Tek Finish
  - Completely VOC neutral
  - Renewable w/ Warranty intact
  - Highest possible stability w/ slice cut face
  - PureCore RIGID Technology
  - Pure Virgin Vinyl & 60% Stone Aggregate
  - Waterproof Core
  - Lifetime Structural Guarantee







# CHAPARRAL

ENGINEERED HARDWOOD FLOORING

AN  
AMERICAN  
ORIGINAL

The Chaparral Collection is our most hand-crafted, rustic and sculpted floor. This collection features wood species from the Northern forest region in America, characterized by its slow-growth, highest quality hardwood timber with fine graining.

The planks are finished in beautifully warm and rich colors to emphasize the tight graining characteristics. Our 2.5mm rotary-cut style combined with wide, 7 inch planks and longer random lengths up to 6'2" creates an expansive, exclusive and timeless design that will enhance any interior space.

PLANK DIMENSIONS: 7" x 6'2" RL



SAGEBRUSH HICKORY



TACKROOM HICKORY



PENDLETON HICKORY



STETSON HICKORY

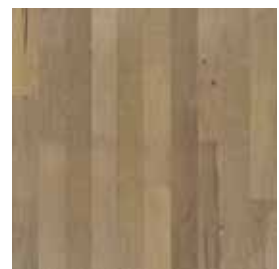

CORRAL HICKORY



WRANGLER HICKORY



CHAPS MAPLE



RUSTLER MAPLE

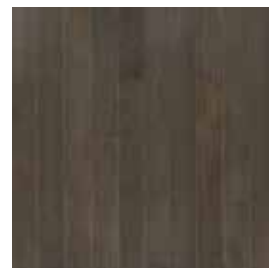

LAREDO MAPLE

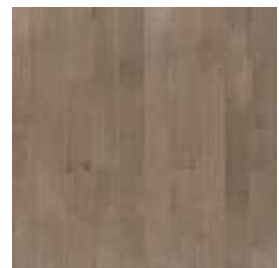

DURANGO MAPLE







PENDLETON HICKORY



DURANGO MAPLE



“We really love the floor. The 7” planks are beautiful and covered the area faster than narrower planks. I did not find any flooring pieces in the order that were unsuitable to install because of blemishes. Being hand-scraped/distressed flooring probably helped but the fact remains that it is a beautiful material that looks great.”

- Steve D.  
Homeowner, Geneseo IL

WRANGLER HICKORY



**BENEFITS**

- TrueMark® Poly- 9 Coats of Ultra Clear Finish
- Completely VOC neutral
- Renewable w/ Warranty intact
- MG2 - 2 Guaranteed sandings
- Highest possible stability w/ Rotary cut face
- Guaranteed Third Party Certification
- Truecore® - Renewable Resources
- Green Certification
- Lifetime Structural Guarantee





CORRAL HICKORY

# SILVERADO

ENGINEERED HARDWOOD FLOORING

SIMPLY  
TRADITIONAL

Warm, rich stains combined with the tight graining of birch add a refined distinction to our Silverado Collection. The wide (6") planks are softly sculpted by hand with our 2.5mm rotary-cut style, and crafted with a pillowed edge in order to provide a timeless, old-world and polished look.

The satin Truemark® finish provides durability to these attractive and traditional floors.

PLANK DIMENSIONS: 6" x 6'2" RL

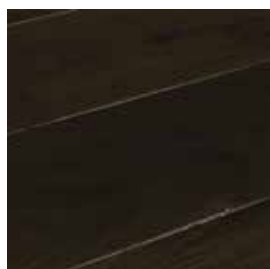

DARK CHOCOLATE BIRCH



DRIFTWOOD BIRCH

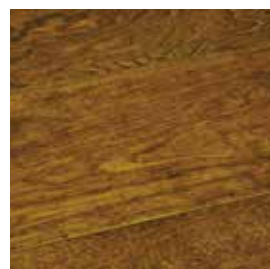

MINK BIRCH

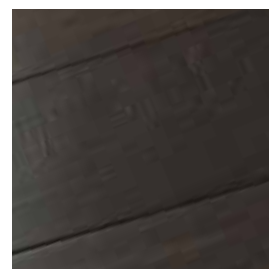

ROSEMARY BIRCH



CANVAS BIRCH



STOUT BIRCH



THYME BIRCH



TOBACCO BIRCH

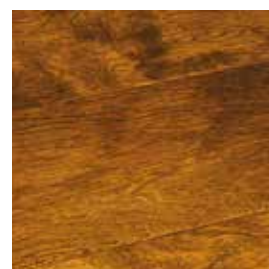

WHISKEY BARREL BIRCH



RUM BIRCH













“Just wanted to let you know how much we love our Hallmark hardwood flooring in our house. We have the Silverado Dark Chocolate in our foyer and throughout our first floor, we get compliments all the time in how great they look.”

- Angelica R.  
Homeowner, Ellicott City MD

#### **BENEFITS**

- TrueMark® Poly- 9 Coats of Ultra Clear Finish
- Completely VOC neutral
- Renewable w/ Warranty intact
- MG2 - 2 Guaranteed sandings
- Highest possible stability w/ Rotary cut face
- Guaranteed Third Party Certification
- Truecore® - Renewable Resources
- Green Certification
- Lifetime Structural Guarantee

# ORGANIC

## SOLID HARDWOOD FLOORING

### REAL RECLAIMED DESIGN

Handcrafted with a texture that thrills both your feet and eyes, the reclaimed design of the Hallmark Organic Solid wood floor carries a sense of history and charm. Creating a perfect complement to contemporary interiors while also accentuating a vintage look, these floors feature a reclaimed design with planks of random widths and lengths, infusing any interior space with an inviting sense of warmth.

This innovative type of solid wood flooring, with its genuine wood texture and natural patina, is unique to Hallmark Floors.

PLANK DIMENSIONS: 3¼", 4" x 6'2" RL



CARAWAY OAK\*



MASALA OAK\*



NONI OAK\*



SAFFRON RED OAK



CLOVE HICKORY



MOROCCAN HICKORY



TULSI HICKORY



CASSIA MAPLE



CARDAMOM MAPLE

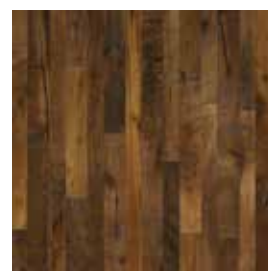

TAMARIND WALNUT

\*FUMED FLOOR  
FOR MORE INFORMATION ABOUT FUMED PRODUCTS, SEE PAGE 50.





RUE  
DU SQUARE

COLLE  
PAULO PRATSU

LABASTIDE



“We absolutely love our new Hallmark Organic Hardwood Flooring! Every piece is unique in color variation and texture! We have a mid century eclectic style and it blends perfectly! Easy to maintain which is essential with 4 boys! We would definitely recommend to anyone wanting hardwood floors that are different from all others!”

- Kim K.  
Homeowner, Le Mars IA

#### BENEFITS

- Nu Oil® Finish - No recoat at time of install
- High stain protection & color retention
- Completely VOC neutral
- Renewable w/ Warranty intact
- Highest possible stability w/ solid sawn faces
- MG4 - 3 Guaranteed sandings
- Guaranteed Third Party Certification
- Green Certification
- Lifetime Structural Guarantee

MOROCCAN HICKORY



TULSI HICKORY









# CRESTLINE

SOLID HARDWOOD FLOORING

SIMPLY  
SAVVY

The new Crestline collection has a traditional hardwood look with wire brushed texture, handcrafted edges, and sculpted profile creating more visual interest on the wide 5" surface. The range of warm, rich historic-European inspired colors and timeless tones provides a perfect color pallet. The hickories bring a wildly beautiful grain pattern, where the oak floors have the classic tighter wood grain with subtle color variation from plank to plank. Crestline has Hallmark's Nu Oil® protective low sheen finish which provides beautiful grain clarity.

PLANK DIMENSIONS: 5" x RL

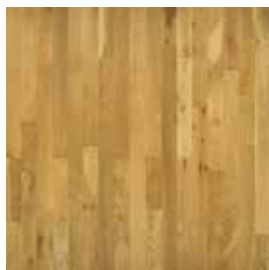

AUGUSTA OAK\*



GENEVA OAK



MONTBLANC OAK



SHASTA OAK



MONROE OAK\*

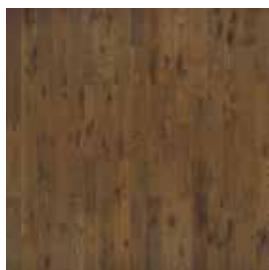

PORTER OAK



SANFORD HICKORY

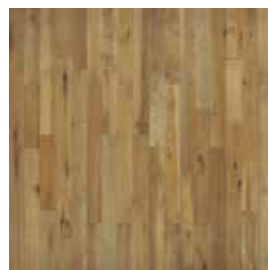

RAINIER HICKORY



HOOD HICKORY

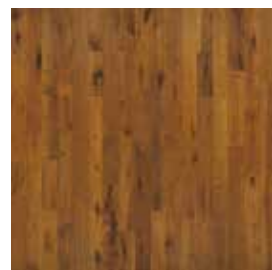

STRATTON HICKORY

\*FUMED FLOOR  
FOR MORE INFORMATION ABOUT FUMED PRODUCTS, SEE PAGE 50.





**BENEFITS**

- Nu Oil® - No recoat at time of install
- Best stain protection & color retention
- Completely VOC neutral
- 100% Renewable w/ Warranty intact
- MG4 - 3 Guaranteed sandings
- Highest possible stability w/ solid sawn faces
- Guaranteed Third Party Certification
- Highest Green Certification
- Lifetime Structural Guarantee









# QUALITY IN EVERY GRAIN

Our collections are small batch, hand-touched & not mass produced, and are always designed with fashion in mind. The subtle nuances that make Hallmark Floors unique are all done by hand and inspired by the natural graining of the wood. The 100% hand scraping that imitates turn-of-the-century flooring and the multi-step weathering techniques beautifully highlights the inherent characteristics found in nature. By layering all of the processes together, it enhances the style and cut of the plank.

## Engineered Hardwood Construction

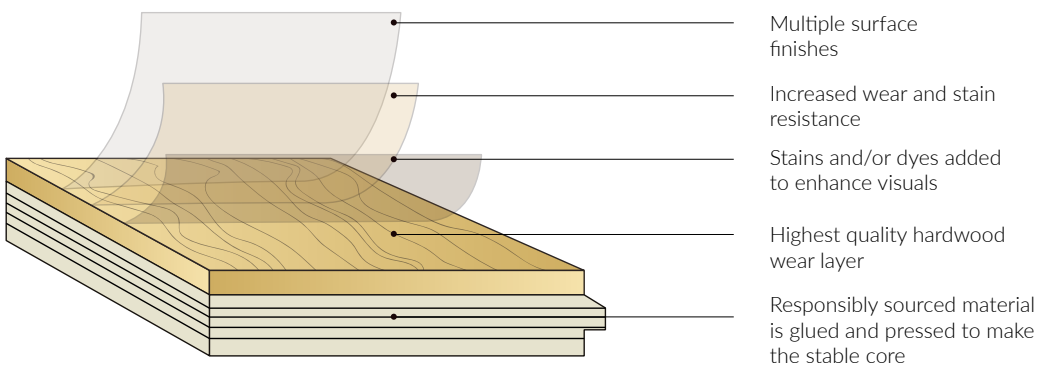

Hallmark Floors' engineered hardwood floors is constructed with an ultra thick wear layer has the same usable surface as 3/4" solid hardwood flooring, which allows 3 guaranteed sandings. Sliced and rotary veneer layers allow up to 2 guaranteed sandings.

## TrueCore® Construction

Hallmark Floors uses only true hardwood veneers and TSCA Title VI glues for the center-ply in our engineered floors' hardwood construction. The center veneers are cold pressed, then hot pressed using tremendous pressure. This process makes the eco-friendly center core harder and more proportionally stable.

- Higher Stability
- Higher Density
- Higher Strength
- Higher Indoor Air Quality

Truecore® is third party verified and surpasses the TSCA Title VI emission requirements.

## TrueCore® 2 Construction

Made from quarter sawn pine lamellas attached to the surface wear layer. Providing 2 key performance enhancing features:

1. Quarter sawn pine lamellas create 25% more dimensional stability with the same indentation resistance as hardwood for optimal structural strength.
2. A 1:5 core to wear surface ratio with an additional applied sealant to the underneath of the plank creating the highest optimum dimensional stability in our plank.

Rapidly renewable core comprises 80% of the volume of the plank, for best management of forest resources. 90 degree side rail design, for precision tongue & groove, providing smooth, clean, simple installation.

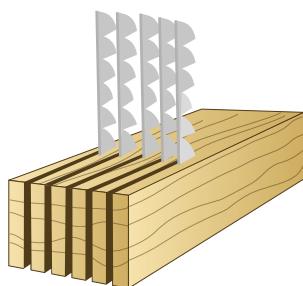

## Sawn-Cut Style

Experts in the industry agree that sawn-cut provides the best quality, stability & visuals for solid & engineered floors. Sawn-cut engineered floors allow for the thickest veneer (4mm) with the highest degree of stability. Engineered sawn-cut wear layers are the ONLY engineered floors that are equal to solid wood floors.

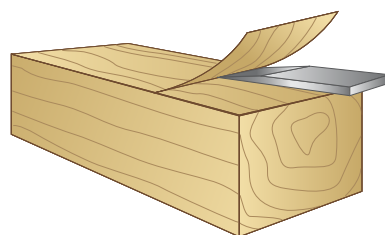

## Slice-Cut Style

Slice-cut features the same beautiful look as sawn cut veneers and is the second most common way to create a wood veneer, it's just in thinner layers (2mm or less). This creates stunning visuals while still providing stability for engineered wood floors.

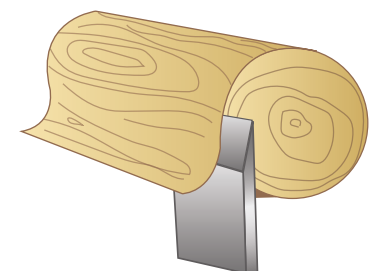

## Rotary-Cut Style

The rotary style has a completely different look than sawn-cut. Rotary-cut top layers accentuate the natural grain pattern and have a more pronounced appearance. The random grain visuals are a reflection of how the wood is processed.





### Nu Oil® Hybrid Oil Finish

Nu Oil® incorporates new hybrid technology, creating a highly durable, stain and fade resistant finish, all with a limited lifetime warranty. Nu Oil® is easier to maintain than traditional oils and does not require an immediate re-coat at time of install.



### TrueMark® Glaze Tek Finish

Four coats of hand applied base and accent colors, combined with twelve coats of finish achieve a depth and richness unparalleled anywhere in the hardwood flooring industry. Nano technology is incorporated into the surface and fortified with aluminum oxide for a finish so durable it carries a limited lifetime warranty against wear through.



### TrueMark® Poly Finish

By using the latest technology in finish systems our TrueMark® Poly Finish is unsurpassed in ensuring the most protective, clear & easily maintainable coatings available for even the toughest of families. Hallmark Floors uses revolutionary nano technology in the surface coats to maintain the beautiful appearance and durability of the surface finish.



### Fumed Floors

Fuming is a natural, accelerated aging process used to enhance the dark and light shades within every wood plank and batch. Fuming simply deepens the natural colors and highlights the contrast of the wood planks without the use of stain. This process creates a naturally richer, darker and clearer floor with a higher contrast of color. It's created by adding a natural oxidizing agent in a controlled environment to react with the naturally present tannins in the wood.

No two planks will be identical after the process, and the intensity and tone of the color will depend on the length of time the wood is treated and the amount of tannins in the wood.

Floors made from fumed hardwood are beautiful, lively and one of a kind, featuring great color variation with a unique high contrast, just like the floor in the beautiful bedroom in the picture.



### Light Exposure & Natural Changes

Varying changes (patina) can occur when wood is exposed to UV rays from sunlight, florescent, LED, and incandescent bulbs. Window coverings, UV resistant tint, solar screens can minimize but not eliminate this natural occurrence. Certain species are more susceptible to light & development of varying degrees/shades of patina, due to their high content of natural oils.

Hallmark hardwood floors are created to showcase the natural beauty of wood. As such, the planks will contain natural mineral deposits/streaking, and both closed and filled knots. Wood is a natural product that features distinct color and graining. Each board is unique in its characteristics and will vary from piece to piece. Each board can vary from a clean to rustic visual.



### Heartwood & Sapwood

The difference between the inner part of the tree (heartwood) and the outer part of the tree (sapwood) can be seen as variations of light and dark. The natural contrast between heartwood and sapwood plays a major role in the color of wood floors. Variations can occur from board to board, as well as in the same board. This occurs naturally, and is not an "unfinished" board.

Staining wood floors can diminish the appearance of heartwood and sapwood, but it doesn't entirely hide these natural characteristics. The stain helps to blend the natural contrasts together. It doesn't eliminate it. Fuming has the opposite affect on heartwood and sapwood. Fumed floors are designed on purpose to magnify the natural contrast.



### Order Samples & See Our Floors in Your Home With The Room Visualizer

Samples are provided as a courtesy to architects, interior designers, other building industry professionals and homeowners. [Samples@hallmarkfloors.com](mailto:Samples@hallmarkfloors.com)

Because wood is a natural material, every plank of Hallmark Hardwood flooring will have a unique appearance, often with naturally-occurring variations in color, texture and grain patterns. Samples and online photos show only a small example of the product's appearance and they may not fully be representative of the range of color, texture and grain variations which can occur. It is recommended that a box of flooring be purchased and seen on-site prior to ordering floors for your home or renovation.

See Hallmark Floors in your home with our new virtual design tool on our website - See endless possibilities.



[SAMPLES@HALLMARKFLOORS.COM](mailto:SAMPLES@HALLMARKFLOORS.COM)

888-551-0888

[WWW.HALLMARKFLOORS.COM](http://WWW.HALLMARKFLOORS.COM)